



WATER LEVEL/TEMPERATURE

SENSOR, WLTS. Series 3791 - 3798

These sensors, based on measuring the hydrostatic pressure and water temperature in a fixed submerged position, are designed to be used with Aanderaa Dataloggers and Display Units.

The Water Level Sensor consists of:

- Pressure Sensor with Thermistor
- Cable with Airpipe
- Compensating Unit

The sensors can also be delivered as averaging versions which is given suffix A in the part number. These versions will minimize the influence of ripples or waves on the measurements.

Accurate monitoring of tide and the water level in ports, coastal and inland waters, rivers and boreholes is of great importance to many practical projects. This series of water level or tide monitoring sensor measures the hydrostatic pressure caused by the head of water above them. The influence of barometric pressure on the sensors is compensated for by applying air pressure to one side of the transducer through an air pipe and compensating unit. The sensors contain, in addition to the sensing element, a temperature compensating and a range reducing network.

The entire electronic circuit is mounted on a board inside the Pressure Sensor and molded into Scotchcast. Other parts exposed to water are made of titanium and this forms a compact and rugged sensor with no corrosion problems.

The sensing element of these units, a small silicon chip with a thin membrane at the centre, is subjected to atmospheric pressure on the one side and water pressure on the other. Four diffused resistors on the chip, in the form of a Wheatstone bridge, give an output signal proportional to the differential pressure. The consequence of using monolithic technology

is a sensor with low ageing, small hysteresis and great resistance to mechanical shocks and vibrations. The output from this sensor is in the VR22 Aanderaa standard. The sensor has a thermistor measuring the water temperature and the output is also VR22.

The averaging versions is designed to monitor water level or tide where waves and ripples may disturb the measurements. In this version the signal from the sensing element is sampled every second and a microcontroller calculates the average value at the end of each measuring cycle. This continuous averaging of the pressure reduces the fluctuations caused by ripples and waves. The current consumption is 1.0 mA continuously and the output is the SR10 Aanderaa standard.

The sampling interval between measurements is controlled by the data logging system and can be set in fixed steps from 1 minute up to 3 hours.

The sensors tolerates operating submerged in purified kerosene.

SPECIFICATIONS

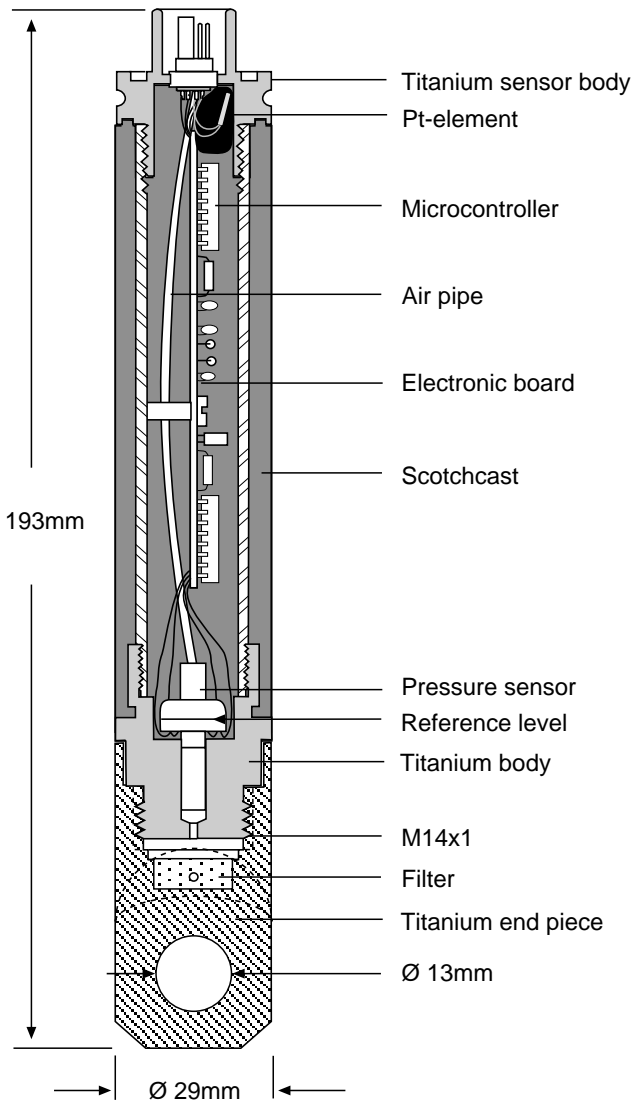

Two versions are available;
 The Momentary Version 3791-98 and the
 Average Since Last Version 3791A-3798A

Pressure: Sensor Output: VR22 (3791-98)
 Sensor Output: SR10 (3791A-98A)
Standard Ranges: 3791A: 0 to 10 m(0-100kPa)
 3796A: 0 to 5 m (0- 50kPa)
 Other ranges on request
Accuracy: ±0.2% of range
Resolution: 0.1% of range

Temperature: Sensor output: VR22
Range: -2 to + 40°C
Accuracy: ±0.1°C
Resolution: 0.05°C
Response time: 25 seconds

Electrical Connection: 10-pin Receptacle mating Cable with Air pipe 3664

Current Consumption:
 Momentary version: 1.0 mA when monitoring
 Average version: 1.0 mA continuous

Operating Temperature: -2 to + 40°C
Material and Finish: Scotchcast and titanium
Degree of Protection: IP 68
Weight inc.accessories: Net weight 2.6 kg; Gross 3 kg
Packing: Cardboard box, 390x230x250mm
Warranty: Two years standard against faulty materials and workmanship

Note! Our standard warranty (2 years) is not applicable in cases where breakage or malfunction occurs to the cable during installation or when caused by excessive wear or other external forces.

ACCESSORIES: Cable w/ Air Pipe 3664. The length is relative to the pressure range, Compensating Unit 3848 and Connecting Cable 3282C 0.5m

Compensating Unit 3848

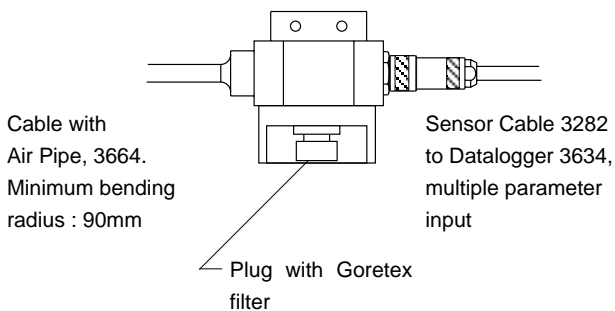

PIN CONFIGURATION

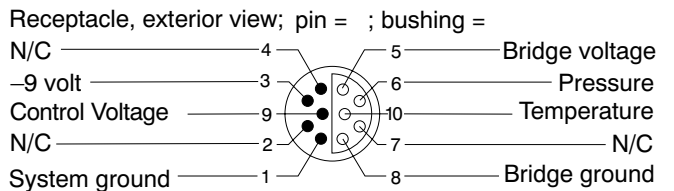

CALIBRATION

Pressure Sensor Type:

Range 0– kPa Diff. Serial No:

The sensor is connected to a Datalogger 3660 and calibrated against a Budenberg 240 dead weight tester. The following pressures gave the readings N:

Pressure

kPa					
N					

These readings give a set of coefficients that must be used when converting the raw data reading (N) to engineering units.

Coefficients for Pressure (kPa)

A		C	
B		D	

Formula for converting Pressure in kPa to Water Level in meters:

$$\text{Water Level (m)} = \frac{(A + BN + CN^2 + DN^3)}{d \times g}$$

A, B, C, D = coefficients given in the sensor's calibration sheet.

N = raw data value measured by the datalogger.
 d = density of water (gram pr. cm³). Depending on its salinity and whether it is fresh or salt water.
 g = gravity. Depending on where the measurements are taken (m/s²).

Coefficients for Water Level in meters (d = 1, g = 9.80665)

A _m		C _m	
B _m		D _m	

How to calculate an A_m coefficient for a Specific Location

Example:

In our example the density is 1 and the gravity is set to 9,80665 (the international standard).

Referring to the calibration sheet for a specific sensor the A coefficient in kPa is -2.842 E - 01

$$A_m \text{ (coeff. in m)} = \frac{A}{d \times g} = \frac{-2.842 \text{ E } - 01}{1 \times 9,80665} = -2,898 \text{ E } - 02$$

The same procedure applies for the B, C and D coefficients.

Date: Sign:

Temperature:

Temp. (°C)				
Reading, N				

Coefficients for Temperature:

A		C	
B		D	

$$\text{Temperature (°C)} = A + BN + CN^2 + DN^3$$

To refer the water level to a Chart Datum:

As tides are reported as surface fluctuations relative to the local Chart Datum it is necessary during the establishment of the tide gauge, to install the sensor at the lowest predicted water elevation.

To refer the water level to a specific reference level or Chart Datum a correction factor must be found.

- 1) Perform a measurement and calculate the water level according to the formula below.
Use the local calculated coefficients A_m, B_m, C_m, and D_m in the formula :

$$\text{Water Level (meters)} = (A_m + a) + B_m N + C_m N^2 + D_m N^3$$

(set a = 0)

- 2) Measure the water level (c in figure) manually with reference to the Chart Datum.
- 3) Subtract the sensor reading (b) from the manually measured water level and the result is the correction factor (a).

Add the factor a when the sensor is positioned above the Chart datum, and subtract the factor when the sensor is below datum.

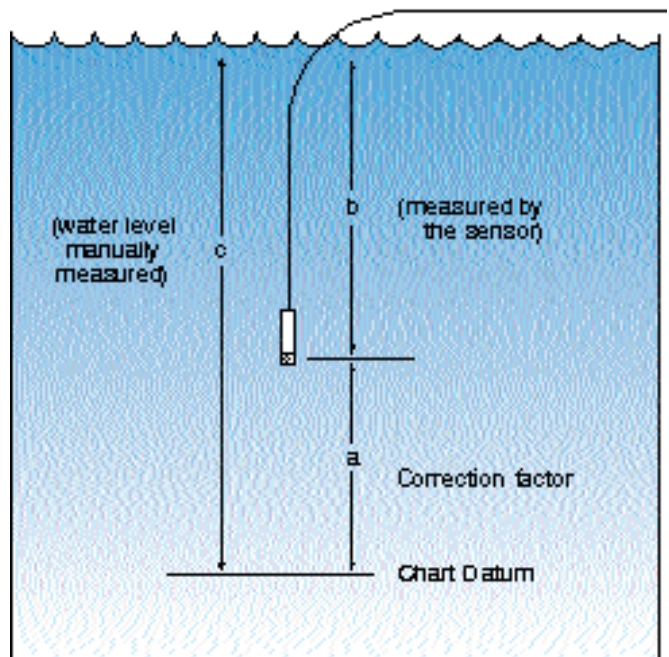

APPLICATIONS

Water Level and Meteorological measurements are often used in combination. Below is a simple system monitoring the most common meteorological parameters at for example in ports or water reservoirs. Data can be stored at site or transmitted in real-time to the user's location either via VHF or UHF radio.

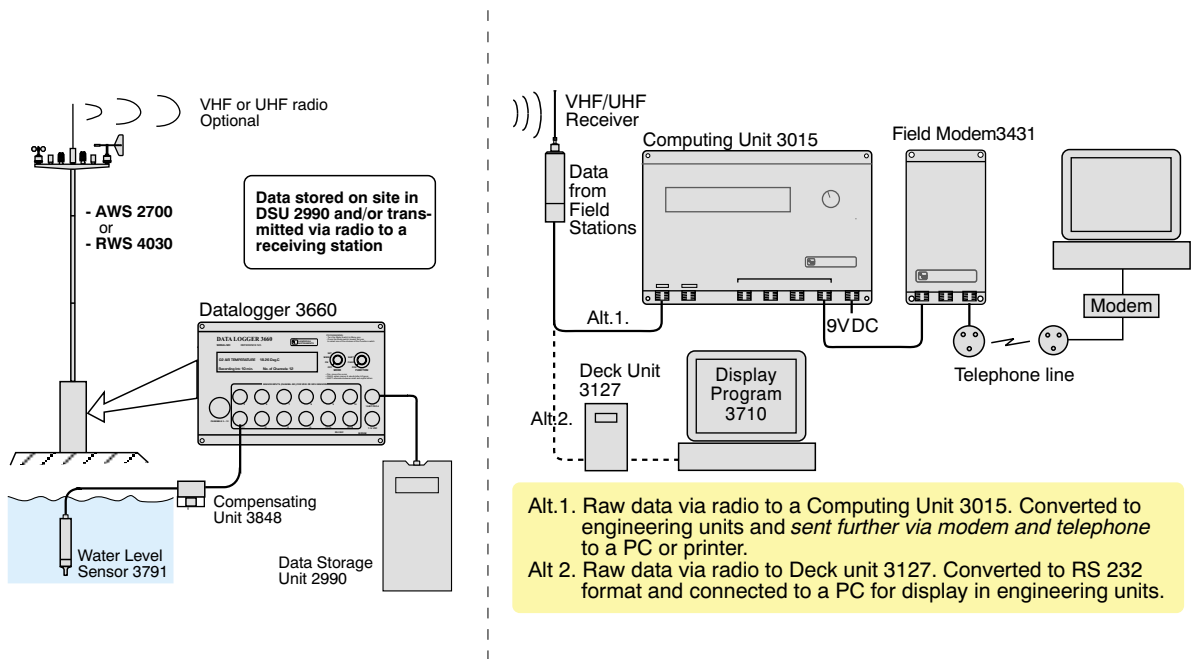
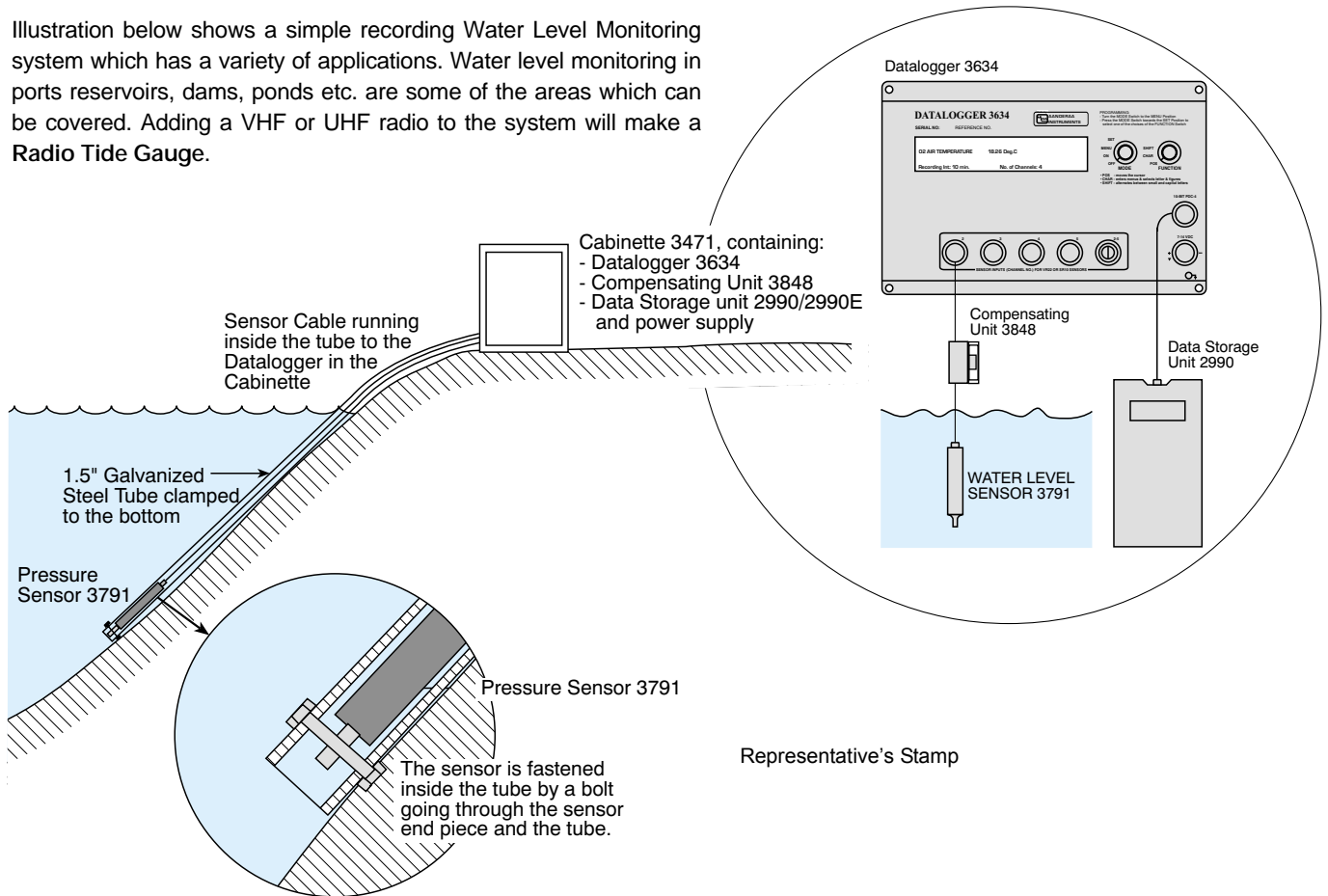

Illustration below shows a simple recording Water Level Monitoring system which has a variety of applications. Water level monitoring in ports reservoirs, dams, ponds etc. are some of the areas which can be covered. Adding a VHF or UHF radio to the system will make a Radio Tide Gauge.



Latest version is on the Internet

PO BOX 160, NESTTUN
5852 BERGEN, NORWAY

FANAVEIEN 13B
5221 NESTTUN, NORWAY

TEL. +47 55 109900
FAX. +47 55 109910

E-MAIL: info@aanderaa.no
WEB: http://www.aanderaa.com