



TEST UNIT 3731

for RCM 9 and RCM 11, DCS
3500/3900/3950/3990/4100 series

A test unit designed to verify the function of the Recording Current Meters RCM 9, RCM 11 and the Doppler Current Sensors, DCS 3500/3900/3950/3990/4100.

The Test Unit is designed to verify that vital parts of the Doppler Current Sensor (DCS) are working correctly. The Test Unit is designed for DCS installed on the RCM9, RCM11 and for stand alone DCS in the 3500/3900/3920/3990/4100 series.

The Test Unit consists of a ring with 4 test transducers suspended by mechanical springs, enabling each test transducer to be pressed against the DCS transducers.

The test transducers pick up some of the energy transmitted by the 'ping' from the DCS. This energy is used to start oscillation of the test transducers. In the receiving stage of the DCS the test transducers are still oscillating and thus transmitting a weak signal back to the DCS.

Two of the test transducers are made of crystals with slightly higher resonance frequency than the DCS transducers, and two are made of crystals with slightly lower resonance frequency. The high frequency corresponds to the received signal when the current direction is towards the DCS, and the low frequency corresponds to a current flowing away from the DCS.

The frequency shift corresponds to a simulated current speed of about 2.83 m/s. The direction of the simulated current is along the centre line between the two low frequency test transducers, marked by a slot in the Test Unit ring.

Procedure for mounting the Test Unit to the DCS:

- Bring the test transducers to their outer position by pulling and turning the grey handles.
- Hold the Test Unit around the DCS and align the test transducers to face the DCS transducers.
- Release carefully the mechanical springs one by one so that the test transducers are in contact with the DCS transducers (ref. drawing on page 2).

NOTE! Moisten the surface of the transducers for optimal contact.

Procedure for use with RCM's/DCS3900/DCS4100-series:

1. Mount the Test Unit to the transducer head/DCS according to procedure.

2. *RCM:* Connect cable 2842 between the Deck Unit 3127 and the watertight receptacle on the RCM. Set the RCM to 3 channels, continuous mode, and start recordings. Switch the Deck Unit to ON.

Stand-alone DCS: Connect cable 3863 between the Datalogger 3634 and the stand-alone DCS. Switch the Datalogger to at least 3 channels for readings (The datalogger will power the DCS).

3. Align the instrument/DCS and the Test Unit so that the orientation slot is in the north direction.
4. Always disregard the first two readings. Read the Current speed from channel 2 on the Deck Unit or Datalogger. Read the Current direction from channel 3. (a raw data reading of 0 corresponds to 0°, north direction).

NOTE! The readings should be according to specifications given on page 2.

5. Dismount the Test Unit and rotate it 180° without moving the instrument/DCS. Remount the Test Unit to the instrument/DCS.
6. Read the Current speed and direction, ref point 4 (a raw data reading of 512 corresponds to 180°, south direction).

Tilting the instrument/DCS corresponds to a slight increase in current speed readings:

- 10° tilt corresponds to 2% increase in reading.
- 35° tilt corresponds to 8% increase in reading.

Test Unit used on Seaguard® RCM

Seaguard® RCM is based on the new ZPulse technology. This is a two frequencies DCS and the test unit only verify the lowest frequency.

The procedure for testing the sensor is equal as described above except the direction will be opposite and the absolute current speed will be approximately 95 cm/s.

Specifications

D320 - July 2010

Test Unit used with RCM:

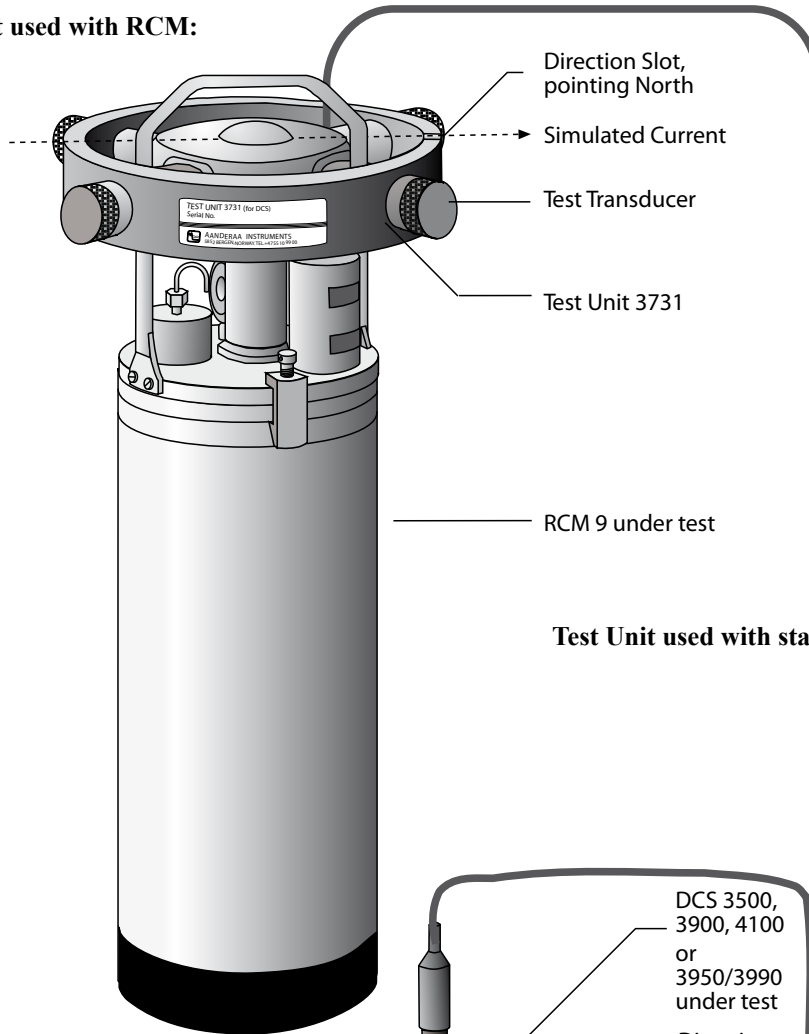

Read-out unit during test

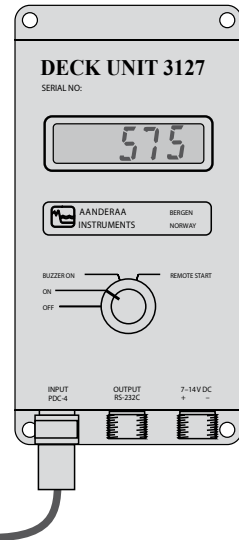

Test Unit used with stand-alone DCS:

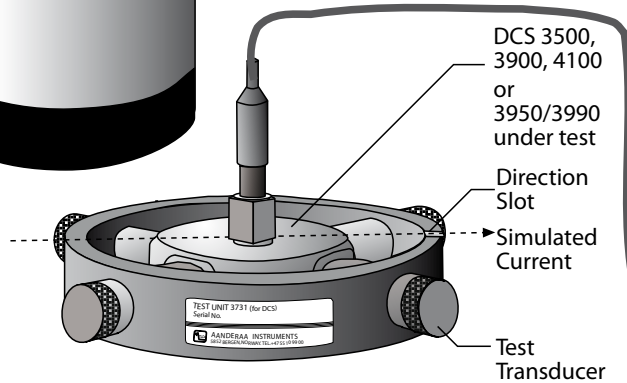

Test Unit 3731

Datalogger 3634

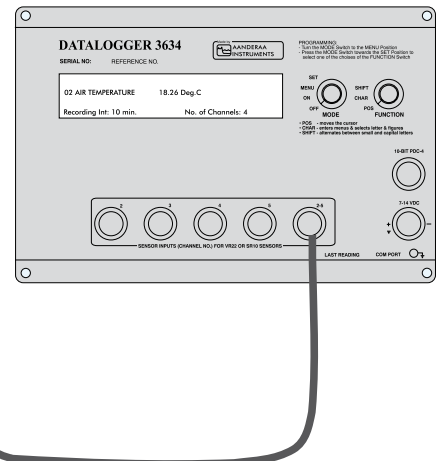

Current Reading:

Speed: **DCS3500,DCS3900A/RA,4100A/RA**
DCS3950,RCM 9 (with DCS3620):
 Raw data: 540 - 590 (264-288 cm/s)
DCS3900/R,DCS3990,DCS3920,DCS3820,
DCS4220,DCS4100/R:

Raw data: 920 - 970 (270-285 cm/s)

Direction: Multiply Raw data readings by 0.3516 for direction in degrees.

Dimensions: 250mm OD 55mm High

Material: PVC ring with 4 transducers molded in Scotchcast

Weight: 400 grams

Latest version on internet

Post Box 34 SLÅTTAUG
 5851 BERGEN, NORWAY
 TEL. +47 55 60 48 00
 FAX. +47 55 60 48 01

<http://www.aadi.no>
 e-mail: info@aadi.no

Representative's Stamp

