



SIGNAL CONVERTER 3429

A unit for converting the Aanderaa signal forms VR22 and SR10 to 0-5V and 4-20 mA signals.

Aanderaa Instruments produces a wide range of environmental and meteorological measuring systems and sensors for the international market. In order to obtain optimum characteristics for field use, the VR22 and SR10 signal standards have been developed and are used in all sensors manufactured by the company.

The Signal Converter 3429 has been designed to allow all Aanderaa sensors, except those supplying averaging values over fixed or extended time periods, to be used with other systems which only accept 0-5V and 4-20mA signals.

The converter consists of an electronic circuit-board molded in Scotchcast, housed in a 32 x 48 x 178mm anodized aluminum cover with three receptacles which together with the necessary plugs makes a watertight unit.

Using a microcontroller, A/D-converter and timing circuitry, the signal converter reads the attached sensor every four seconds.

The received reading is converted and the two corresponding output signals are set. These will remain unchanged until updated by the next reading.

For multiparameter sensors a signal converter is required for each parameter.

The sensor input receptacle, the sensor output receptacles and the power supply receptacle are galvanically isolated from each other.

Some Aanderaa sensors, such as the Wind Speed Sensor 2740, are based on counting pulses. In order to obtain maximum accuracy for low readings from these sensors, it is recommended that the reading system computes averages over longer intervals.

Separate data sheets are available for all Aanderaa sensors.

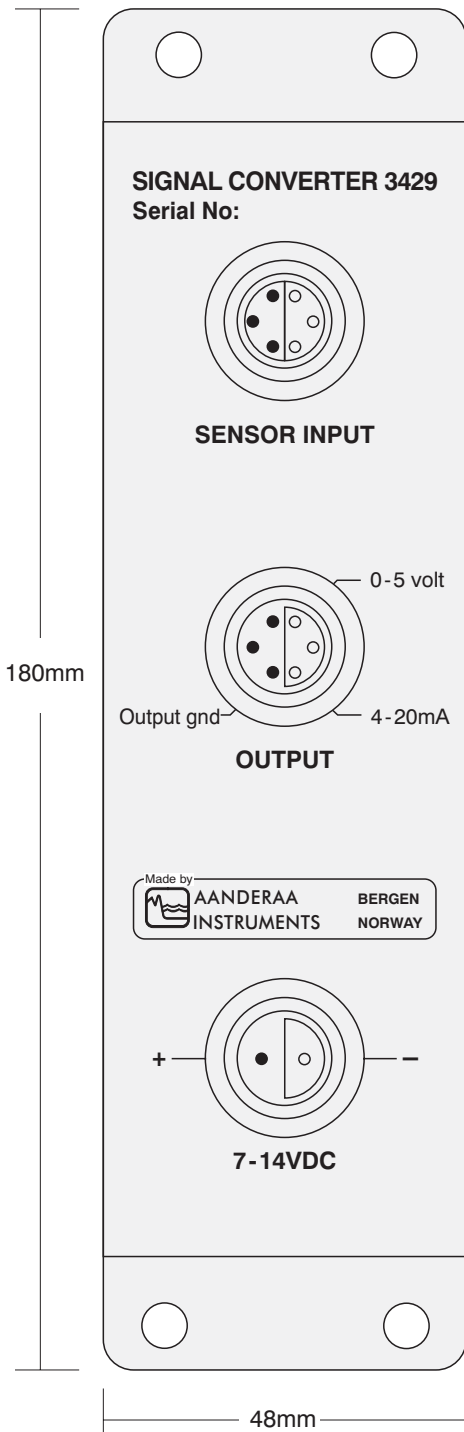

- Input Signal:** Aanderaa standard SR10 or VR22
- Output Signal:** 0–5V and 4–20 mA
(Maximum load 500Ω)
- Accuracy:** ±0.5% of full scale
- Sampling Speed:** One reading every 4 seconds
- Operating Temperature:** –30 to +50°C
- Electrical Connections:** Sensor input:
via Sensor Cable 2842
Output: 6-pin receptacle
Power: 2-pin receptacle
- Current Consumption:** 90 mA maximum. The attached sensor may, in addition, consume up to 100mA
- Supply Voltage:** 7 - 14DC
Do not exceed maximum voltage
- Material:** Aluminum, hard anodized 20μ
- Net Weight:** 320 grams
- Packing:** Cardboard box
- Accessories (included):** Connecting Cable 3484L, 6-pin to free end, 1m; Connecting Cable 3483F, 2-pin to free end, 3m
- Accessories (optional):** Sensor Cable 2842
AC/DC Adapter 3786
Fastening Bracket for 3786
Watertight Plug 2979L, 2-pin
- Warranty:** Two years against faulty materials and workmanship

PIN CONFIGURATION

Sensor Input

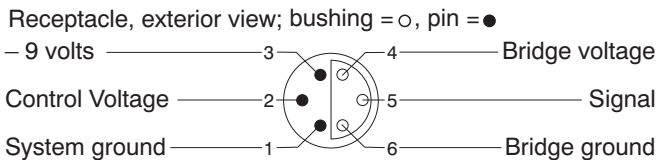

Output

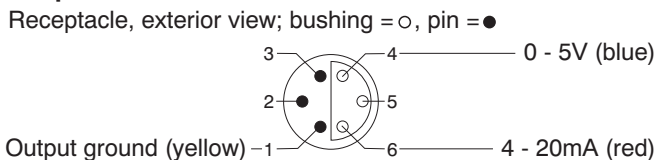

Power, 7 - 14VDC

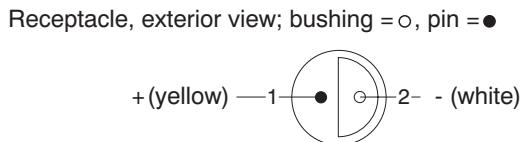

CONVERTING CALIBRATION COEFFICIENTS

Engineering units (m/s, °C etc.) are calculated using one of the formulas: Engineering unit (U_{volt}) = $A' + B'U + C'U^2 + D'U^3$, or Engineering unit (I_{mA}) = $A' + B'(I-4) + C'(I-4)^2 + D'(I-4)^3$ where U is the output from the Signal Converter in volt and the I is the output in milliampere.

The calibration coefficients A, B, C and D given on the sensor's data sheet must be converted into A', B', C' and D' as follows:

Coefficient	0–5 volt output:	4–20 mA output:
A'	= A	= A
B'	= (1023/5) x B	= (1023/16) x B
C'	= (1023/5) ² x C	= (1023/16) ² x C
D'	= (1023/5) ³ x D	= (1023/16) ³ x D

Latest version is on the Internet

PO BOX 34, SLÅTTHAUG
5851 BERGEN, NORWAY

NESTTUNBREKKEN 97
5221 NESTTUN, NORWAY

TEL. +47 55 109900
FAX. +47 55 109910

E-MAIL: info@aanderaa.no
WEB: http://www.aanderaa.com