



ROAD CONDITION SENSOR 3565

A sensor monitoring road surface temperature, wet or dry road, snow coverage and the salinity (freezing point) of the moisture on the road surface.

ROAD CONDITION SENSOR 3565E

A sensor monitoring road surface temperature, wet or dry road and the salinity (freezing point) of the moisture on the road surface.

The surface condition of roads is of great concern to road authorities and road maintenance people. During the winter months it is especially important to be informed of the changing surface conditions to enable road maintenance personnel to take the proper course of action. By knowing the road conditions, the use of anti-icing chemicals may be optimized and in many cases reducing maintenance cost. For these reasons, the Road Condition Sensor 3565 has been developed.

The sensor consists of a cylindrically shaped body molded in a mixture of polyurethane and Portland cement. A set of sensing elements consisting of five sets of four graphite electrodes as well as three transparent polycarbonate rods are visible on the upper surface of the sensor.

A 15 meter long fixed cable with a watertight non-corrosive 10-pin plug connects the sensor to the Datalogger 3660 in the Road Weather Station housing.

The sensor measures up to four important parameters;

- Road temperature
- Wet or dry road surfaces
- Salinity of the surface moisture, from which the freezing point is calculated
- Snow or Not Snow

The temperature sensing element is a platinum resistor. The salinity measurement is based on the four electrode principle. A constant alternating current is applied to the two outer electrodes in each set. If water is present, the two inner electrodes measure a voltage dependent on the concentration of salt. This conductivity measurement is temperature compensated which gives a salinity measurement. These measurements are taken every second and averaged over the sampling interval. The average value indicates the freezing point.

The Wet/Dry Detector also uses an electrode to sense the voltage on the sensor surface. If the surface is wet, it will detect a voltage created by the salinity circuitry.

The Snow Detector is based on optical detection of light transmitted by two light emitting diode. When snow is present, the light from the LED is reflected by the snow and detected by a photodiode.

The sensor must be installed flush with the road surface and outside the wheel path where water will not accumulate. Only a thin film of water should be present for correct salinity measurements. The sensor will be worn down with the surrounding road surface. The sensor is powered by the Road Weather Station.

Specifications

D289 - January 2010

ROAD CONDITION SENSOR 3565

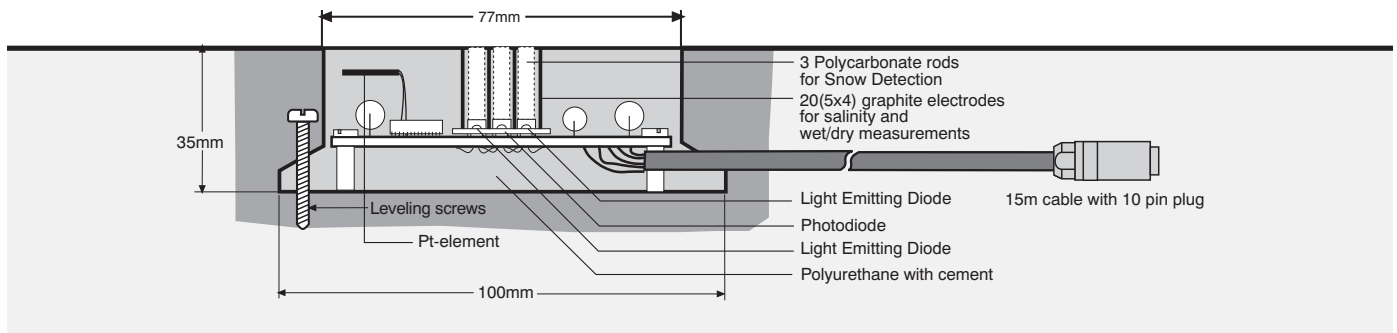

PIN CONFIGURATION

Plug, exterior view; pin = ●; bushing = ○

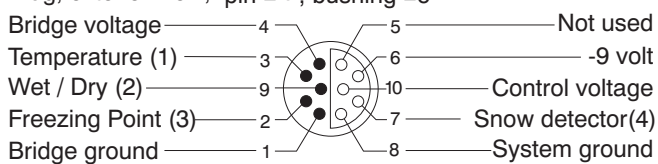

Road Condition Sensor 3565 measures four parameters: Temperature, Wet/Dry, Freezing Point and Snow Detection.

Road Condition Sensor 3565E measures three parameters: Temperature, Wet/Dry and Freezing Point.

1. Temperature sensor:

Range: -43 to +48°C
 Resolution: 0.1°C
 Accuracy: ±0.2°C
 Output: VR22
 Time constant (63%): 4.5 minutes

2. Wet /Dry Detector:

Output: ON/OFF (SR10)
 Reading: 1022 when wet
 0 when Dry

3. Freezing Point:

Output: SR10 (Digital)
 Range: -22.5 to 0°C
 Accuracy: ±10%
 Calibrated for NaCl

4. Snow Detector:

Output: ON/OFF (SR10)
 Reading: 1022 when snow
 0 when no snow
 Detection Level: < 2mm

Current consumption: 2.0mA Average

Operating temperature: -45 to +50°C

Dimensions: Height: 35mm, Dia.: 100mm

Permissible wear: 5mm

Gross weight: 600 grams, including 3m cable

Degree of protection: IP 68

Electrical connection: 15m long, 7.5mm OD cable with 10-pin plug

ROAD CONDITION SENSOR 3565E

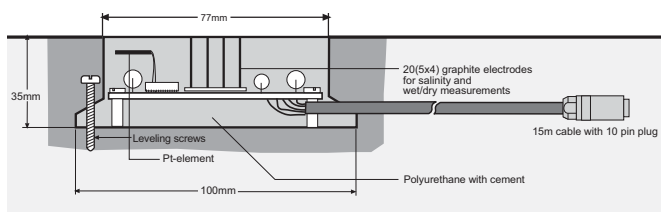

PIN CONFIGURATION

Plug, exterior view; pin = ●; bushing = ○

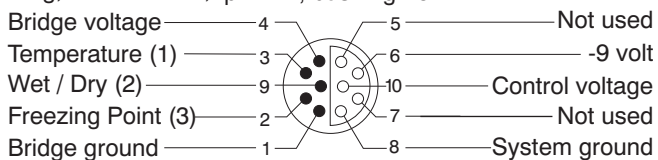

Post Box 34 SLÅTTHAUG
 5851 BERGEN, NORWAY
 TEL. +47 55 60 48 00
 FAX. +47 55 60 48 01

<http://www.aadi.no>
 e-mail: info@aadi.no

Representative's stamp



AANDERAA DATA INSTRUMENTS

AADI, a Nova Analytics company